

PRINCIPAL SPECIFICATIONS

Model Number, BNC	Model Number, SMA	Freq. Range, MHz	Amplitude Balance, dB, Max.	Bandwidth Ratio	Insertion Loss, dB, Max.	Phase Tolerance	VSWR, Max.	Isolation, dB, Min.	Weight, oz.(g) Nom.
QH-7-4.9	QHM-7-4.9	0.1 - 10	1.0	100 : 1	1.5	90° ± 5°	1.3:1	20	16(448)
QH-7-15	QHM-7-15	0.5 - 30	1.0	60 : 1	1.5	90° ± 3°	1.3:1	20	7(196)
QH-7-17	QHM-7-17	2 - 32	1.0	16 : 1	1.0	90° ± 3°	1.3:1	20	7(196)
QH-7-41	QHM-7-41	2 - 80	1.0	40 : 1	1.5	90° ± 3°	1.3:1	20	7(196)
QH-7-126	QHM-7-126	2 - 250	1.3	125 : 1	2.0	90° ± 6°	1.4:1	18	7(196)

General Notes:

1. The QH-7 Series consists of multi-octave models with bandwidth ratios ranging from 16:1 to 125:1. Their function is to split an input signal into two equal amplitude, isolated outputs having a quadrature phase relationship. Conversely, these units may be used to combine two quadrature phased, equal amplitude signals into a single output.

GENERAL SPECIFICATIONS

Nominal Coupling: - 3 dB nom.
 CW Input: 1 W max. (1.2:1 VSWR_{out})
 (0.1 W for QH-7-4.9)
 Impedance: 50 Ω nom.
 Operating Temp: - 55° to +85°C

Typical Performance - QH-7-4.9 Model

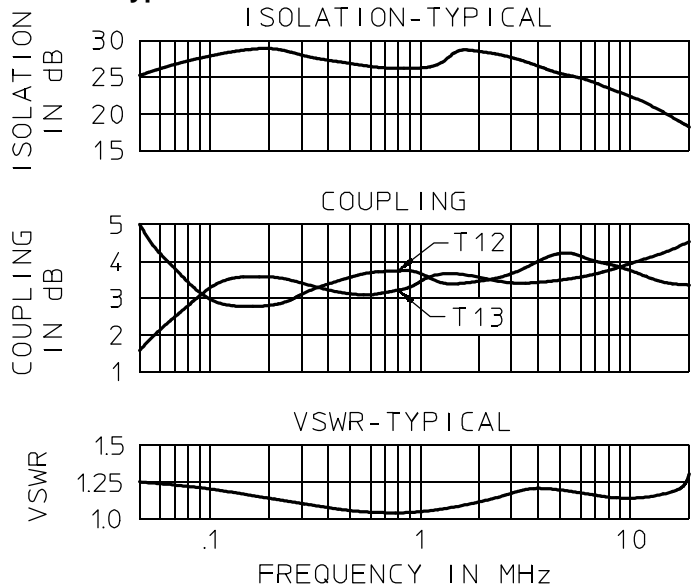

Typical Performance - QH-7-126 Model

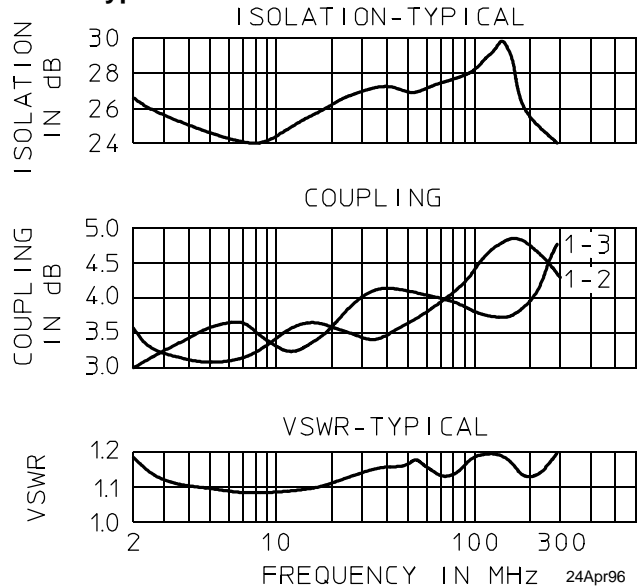

QH & QHM-7 Series 90° POWER DIVIDERS/COMBINERS

100 kHz to 250 MHz / Multi-Section Lumped Element Designs / BNC & SMA Versions



QH/QHM-7 Outlines (except QH/QHM-7-4.9)

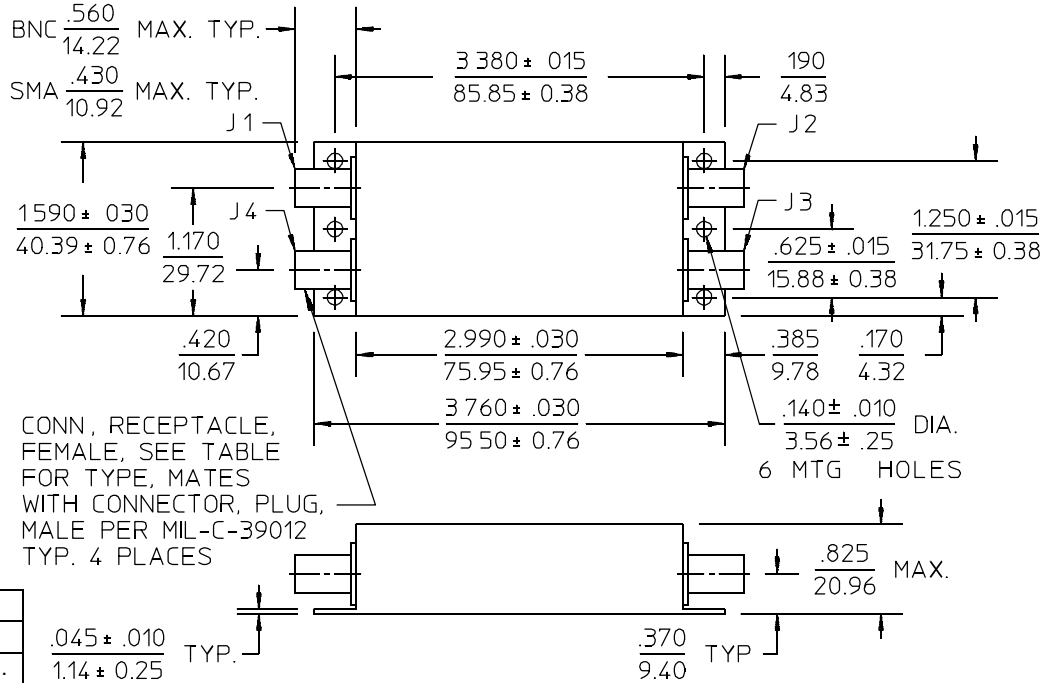

Phasing Diagram - C

	1	2	3	4
1		ref.	+90°	Isol.
2	ref.		Isol.	-90°
3	-90°	Isol.		ref.
4	Isol.	+90°	ref.	

NOTES: 1. Tolerance on 3 place decimals ±.020(.51) except as noted.
2. Dimensions in inches over millimeters.

QH/QHM-7-4.9 Outline

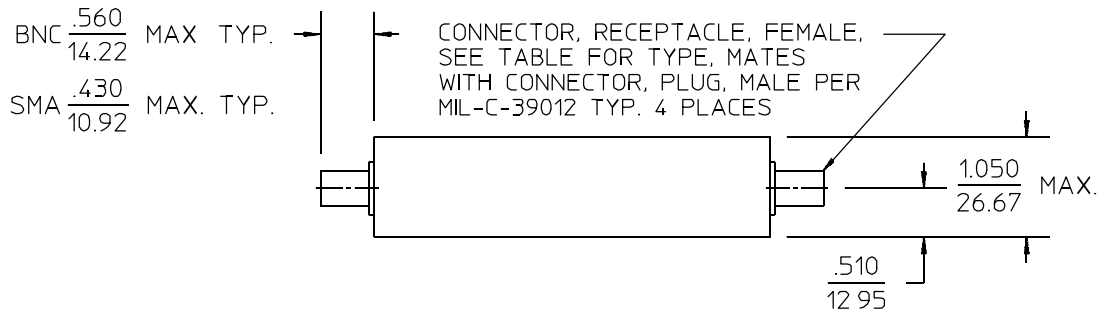

Phasing Diagram - C

	1	2	3	4
1		ref.	+90°	Isol.
2	ref.		Isol.	-90°
3	-90°	Isol.		ref.
4	Isol.	+90°	ref.	

NOTES: 1. Tolerances on 3 place decimals ±.020(.51) except as noted.
2. Dimensions are in inches over millimeters.

24Apr96